



Batteries that last and last

Deep Cycle AGM Batteries

C12-55XDA (12V / 55Ah)



Century AGM Deep Cycle Batteries are the ultimate in deep cycle battery performance, designed to provide longer life and dependable deep cycling capability in the harshest of operating conditions and environments.

The Century Deep Cycle AGM range utilises Absorbed Glass Mat (AGM) technology which absorbs the liquid electrolyte within highly porous glass fibre mat separators. This eliminates loose electrolyte whilst the sealed maintenance free design prevents acid leaks and the need for on-going maintenance. Extra strong grid designs, superior active paste material and robust internal components ensure lower self discharge, superior vibration resistance, longer cycle life and improved recharge capabilities.

Century Deep Cycle AGM batteries are ideal for use in applications where fast recharge, and superior deep cycle capabilities are required, such as recreational vehicles and accessories, dual battery systems, golf carts, electric wheel chairs, mobility scooters and marine systems.

Product Specification

Cells	6	Weight	Approx. 18.0 kg
Voltage	12	Max. Discharge Current	550 A (5 sec)
Capacity	55Ah@20hr-rate to 1.75V per cell @ 25°C	Internal Resistance	Approx. 6mΩ
Operating Temperature Range	Discharge: -20°C~60°C Charge: 0°C~50°C Storage: -20°C~60°C	Terminal	M6 Insert
		Container Material	A.B.S. (UL94-HB)
Normal Operating Temperature Range	25°C ± 5°C	Recommended Max. Charging - Current Limit	16.5A
Float Charging Voltage	13.6 to 13.8 VDC/unit Average at 25°C	Equalisation & Cycle Service	14.6 to 14.8VDC/unit Average at 25°C
Self Discharge	Century AGM batteries can be stored for more than 6 months at 25°C. Self-discharge rate less than 3% per month at 25°C. Please charge batteries before using.	Note: Warranty void if mounted under bonnet	

Unit: mm **Dimension:** 229 (L) x 138 (W) x 211 (H) x 216 (TH) (±2.0mm)

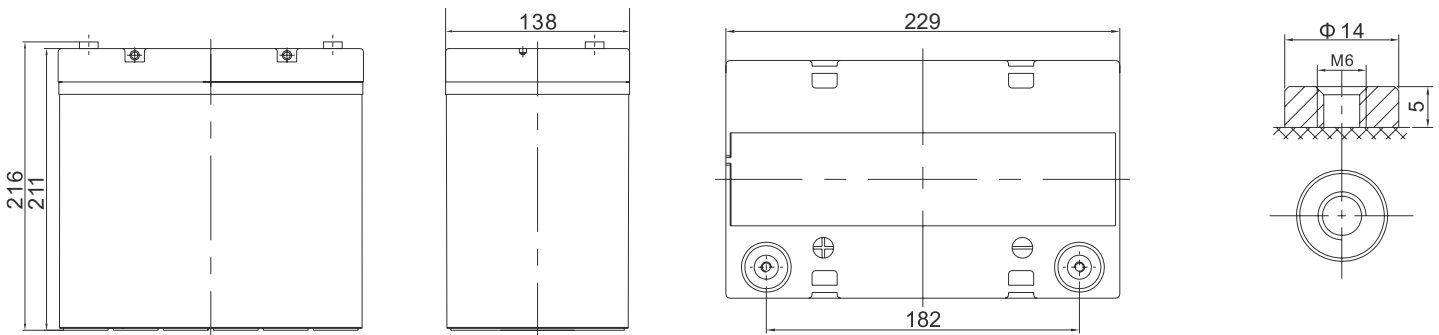

Discharge Current VS Discharge Voltage

Final Discharge Voltage V/Cell	1.75V	1.70V	1.60V
Discharge Current	(A) ≤ 0.2C	0.2C < (A) < 1.0C	(A) ≥ 1.0C

Charge the batteries at least once a month every six months, if they are stored at 25°C

Charging Method

Constant Voltage -0.2Cx2h+2.4~2.45V/Cellx24h, Max.Current 0.3CA

ALL MENTIONED VALUES ARE AVERAGE VALUES.

Constant Current Discharge Characteristics: A (25°C)

F.V/Time	5MIN	10MIN	15MIN	30MIN	1HR	2HR	3HR	4HR	5HR	8HR	10HR	20HR
9.60V	189.6	135.8	98.84	60.72	34.32	19.46	13.78	11.40	8.976	6.559	5.546	2.933
10.0V	184.5	129.3	96.81	59.72	34.16	19.31	13.73	11.35	8.923	6.505	5.492	2.879
10.2V	173.9	124.7	95.29	59.19	33.84	19.16	13.62	11.30	8.870	6.452	5.439	2.826
10.5V	156.1	115.1	90.73	57.71	33.53	19.01	13.57	11.19	8.765	6.399	5.386	2.773
10.8V	140.9	104.9	83.64	55.18	32.74	18.66	13.20	10.93	8.606	6.292	5.332	2.719
11.1V	122.7	93.8	75.02	51.69	31.10	18.36	12.62	10.40	8.237	6.025	5.172	2.559

Constant Power Discharge Characteristics: W (25°C)

F.V/Time	5MIN	10MIN	15MIN	30MIN	1HR	2HR	3HR	4HR	5HR	8HR	10HR	20HR
9.60V	1975	1445	1064	685.2	392.5	230.2	159.0	131.8	103.9	76.11	62.36	32.94
10.0V	1935	1380	1041	676.7	390.6	229.3	158.7	131.5	103.3	75.79	61.72	32.62
10.2V	1827	1334	1027	668.8	387.8	227.2	157.8	130.8	103.0	75.15	61.40	32.30
10.5V	1645	1232	979.6	653.6	384.0	225.1	156.8	129.9	102.0	74.51	60.76	31.98
10.8V	1480	1119	900.1	623.8	374.5	221.8	153.0	126.4	100.4	72.91	60.12	31.66
11.1V	1277	993.8	803.7	584.5	354.8	211.6	145.4	120.4	95.36	70.35	58.20	30.38

All mentioned values are average values.

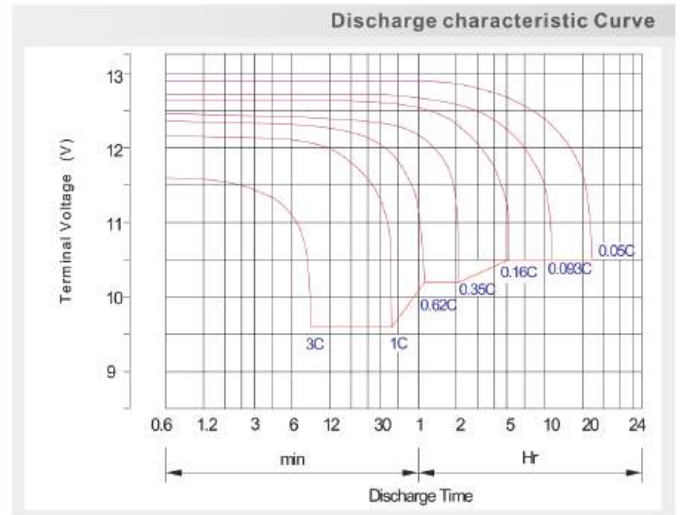
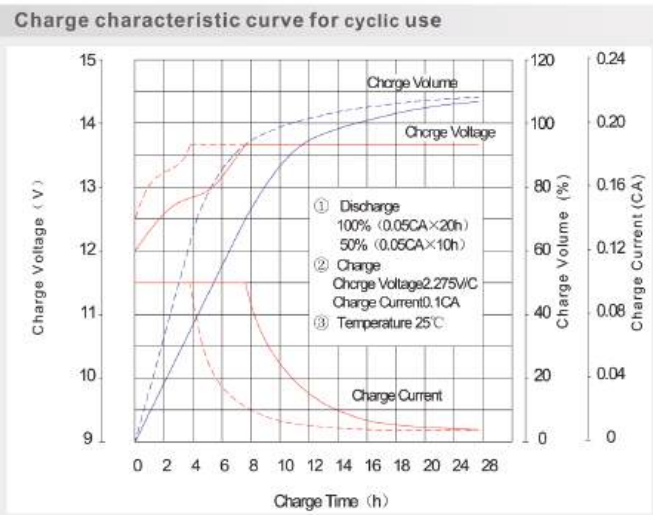
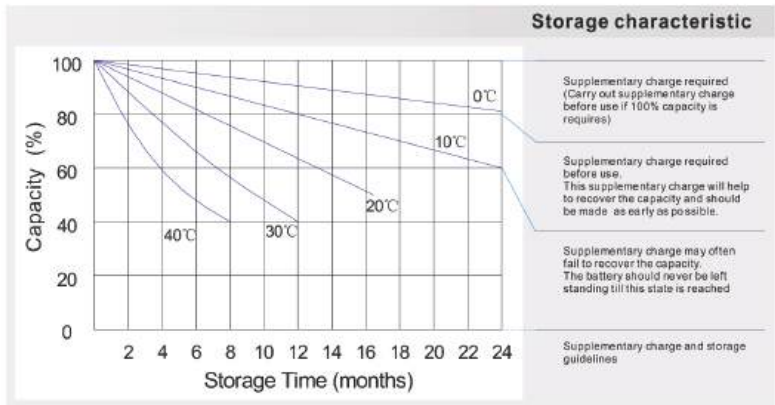
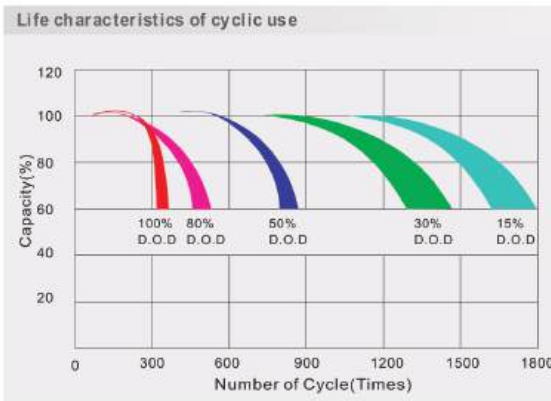

Battery Disposal

This battery is 98% recyclable. Help create a cleaner planet, return your used battery to the original place of purchase or your nearest CenturyYuasa approved Battery Recycling Centre.



Batteries that last and last

For more information visit

centurybatteries.com.au or call 13 22 87
centurybatteries.co.nz or call 0800 93 93 93