

Century PS 5-year VRLA batteries are a range of high performance multi-purpose batteries which provide dependable primary and back-up power in domestic and commercial applications.

Manufactured to the latest International standards using premium grade raw materials and superior manufacturing processes, Century PS batteries provide reliable, trouble-free power in high-service-life applications.

The VRLA (Valve Regulated Lead Acid) recombinant design eliminates the need for regular maintenance and enables fitment in hard-to-reach locations without the loss of performance, capacity or life.

- ✓ Sealed construction with pressure relief system
- ✓ Operation in any orientation (except in an inverted position)
- ✓ Heavy duty grids
- ✓ Low self discharge
- ✓ 98% recyclable



Performance Specifications	
Nominal Voltage	12V
Rated Capacity at 25°C	210Ah (20 hour, 10.8V) 200Ah (10 hour, 10.8V) 170Ah (5 hour, 10.8V) 122.2Ah (1 hour, 9.6V)
Internal Resistance at 25°C	Approx. 3.5mΩ
Maximum Discharge Current	2000A (5 sec.)
Maximum Charge Current	60A
Charge Voltage	Float Charge at 25°C: 13.6V~13.8V Float charge voltage temperature correction factor from standard 25°C: -3mV/°C/Cell
	Cyclic Charge at 25°C: 14.6V~14.8V Cyclic Charge voltage temperature correction factor from standard 25°C: -4mV/°C/Cell
Operating Temperature Range	Discharge: -20°C~60°C Charge: 0°C~50°C Storage: -20°C~60°C
Design life at 25°C	12 years
Storage	Batteries can be stored for up to 6 months at 25°C after which recharging is recommended. For higher temperatures the time interval will be shorter.

Physical Specifications	
Dimensions	Length: 522±2mm
	Width: 240±2mm
	Container Height: 219±2mm
	Overall Height: 224±2mm
Terminal Type	M8 insert
Weight	Approx. 58kg
Container Material	A.B.S

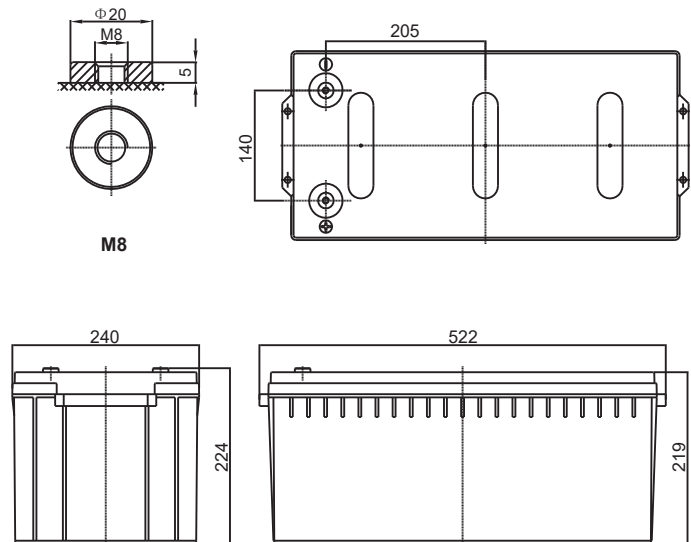

DISCHARGE CHARACTERISTICS

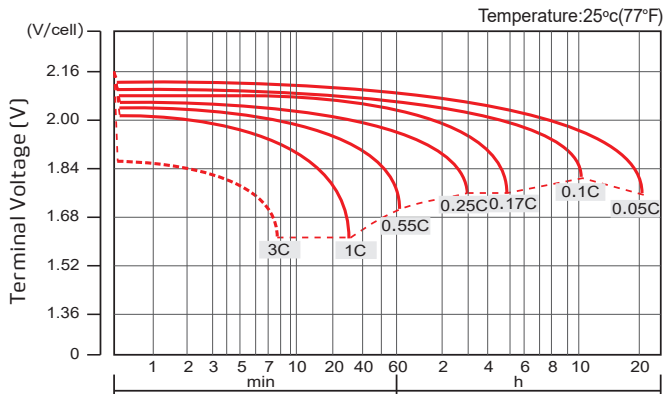

Discharge Time

FLOAT CHARGE CHARACTERISTICS

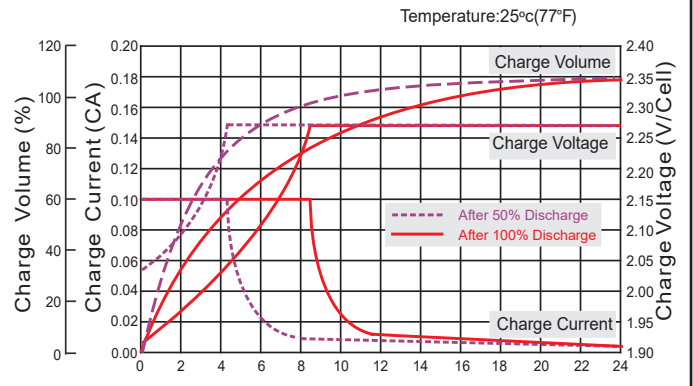

Charging Time (hours)

TEMPERATURE EFFECTS IN RELATION TO BATTERY CAPACITY

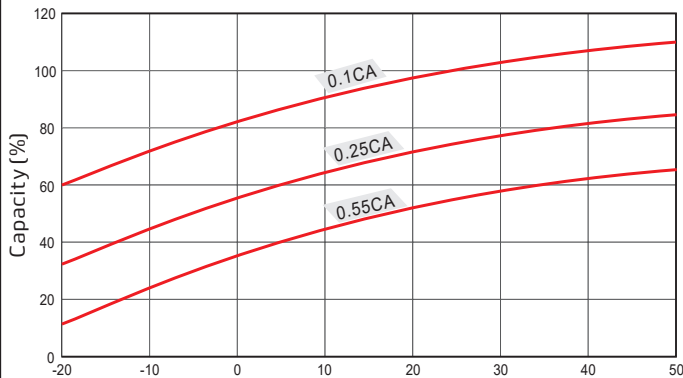

Battery Temperature

FLOAT SERVICE LIFE

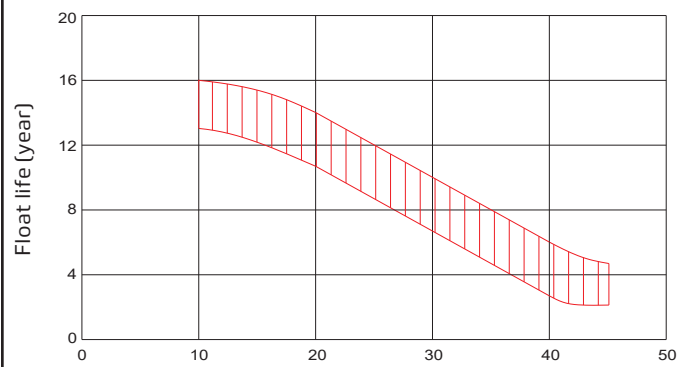

Battery Temperature

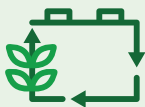

Make a positive change

This battery is 98% recyclable. Help create a cleaner planet, return your used battery to the original place of purchase or your nearest Century Yuasa approved Battery Recycling Centre.

You can find your nearest recycling centre:



1300 650 702
recyclemybattery.com.au



0800 93 93 93
recyclemybattery.co.nz

For more information contact a Century battery specialist:

Australia: 49 Cobalt Street | Carole Park, QLD 4300 | T: 1300 362 287 | centurybatteries.com.au

New Zealand: 259 Church Street | Onehunga, Auckland 1061 | T: 0800 93 93 93 | centurybatteries.co.nz