

PS645

6V

4.5Ah

VRLA

AGM

Century PS 5-year VRLA batteries are a range of high performance multi-purpose batteries which provide dependable primary and back-up power in domestic and commercial applications.

Manufactured to the latest International standards using premium grade raw materials and superior manufacturing processes, Century PS batteries provide reliable, trouble-free power in high-service-life applications.

The VRLA (Valve Regulated Lead Acid) recombinant design eliminates the need for regular maintenance and enables fitment in hard-to-reach locations without the loss of performance, capacity or life.

- ✓ Sealed construction with pressure relief system
- ✓ Operation in any orientation (except in an inverted position)
- ✓ Heavy duty grids
- ✓ Low self discharge
- ✓ 98% recyclable



Performance Specifications	
Nominal Voltage	6V
Rated Capacity at 25°C	4.5Ah (20 hour, 5.25V) 4.26Ah (10 hour, 5.25V) 3.84Ah (5 hour, 5.25V) 2.8Ah (1 hour, 4.8V)
Internal Resistance at 25°C	Approx. 25mΩ
Maximum Discharge Current	68A (5 sec.)
Maximum Charge Current	1.35A
Charge Voltage	Float Charge at 25°C: 6.75V~6.9V Float charge voltage temperature correction factor from standard 25°C: -10mV/ °C Cyclic Charge at 25°C: 7.2V~7.5V Cyclic Charge voltage temperature correction factor from standard 25°C: -15mV/ °C
Operating Temperature Range	Discharge: -15°C~50°C Charge: 0°C~40°C Storage: -15°C~40°C
Design life at 25°C	5 years
Storage	Batteries can be stored for up to 6 months at 25°C after which recharging is recommended. For higher temperatures the time interval will be shorter.

Physical Specifications	
Dimensions	Length: 70±1mm Width: 47±1mm Container Height: 100±2mm Overall Height: 106±2mm
Terminal Type	T1 (4.75mm wide)
Weight	Approx. 0.81kg
Container Material	A.B.S

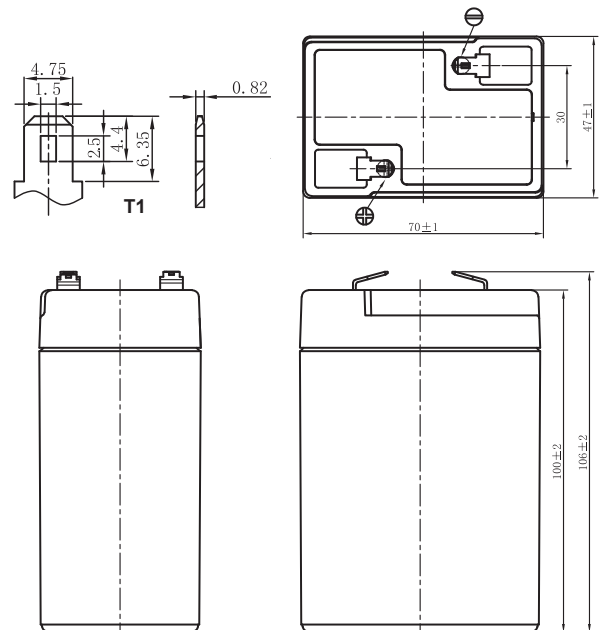

DISCHARGE CHARACTERISTICS

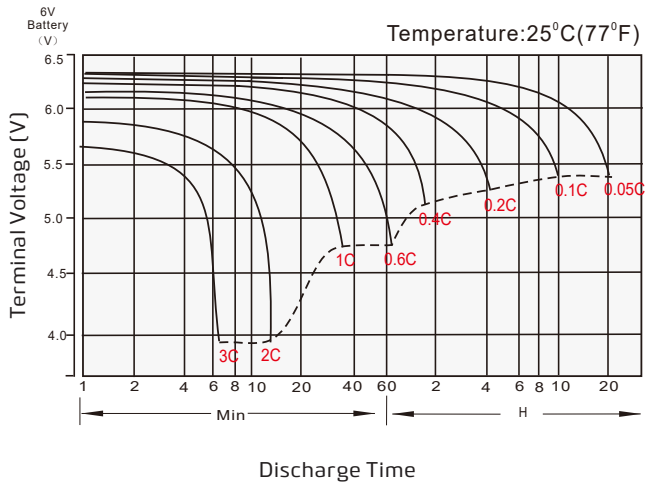

FLOAT CHARGE CHARACTERISTICS

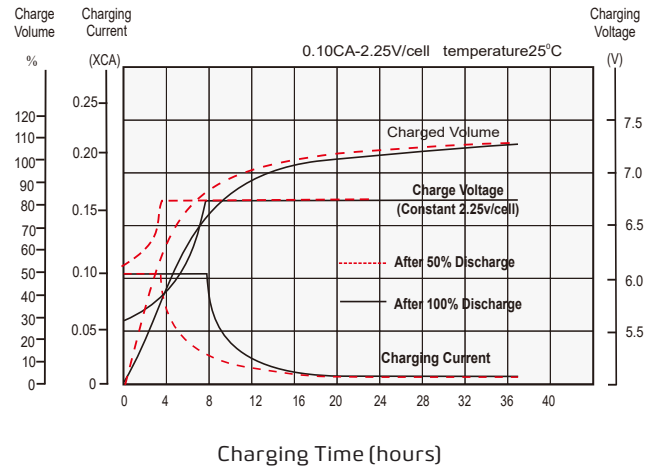

TEMPERATURE EFFECTS IN RELATION TO BATTERY CAPACITY

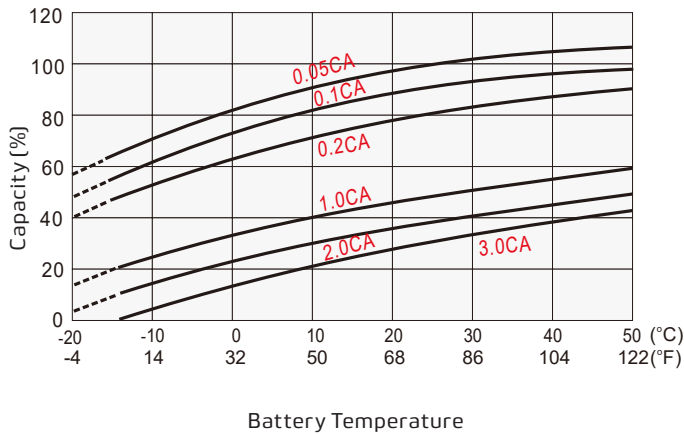

FLOAT SERVICE LIFE

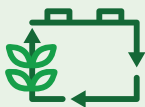
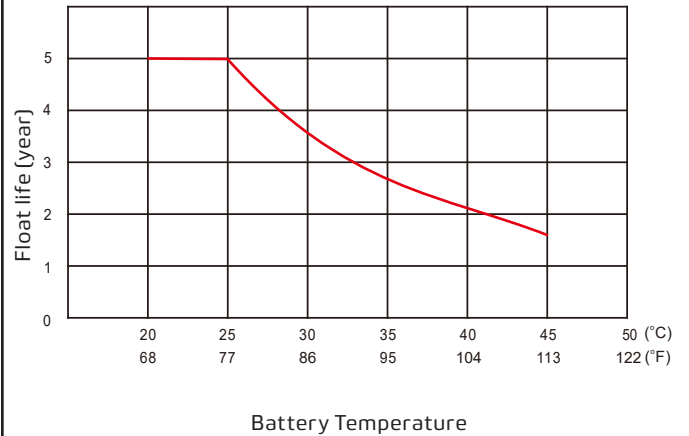

Make a positive change

This battery is 98% recyclable. Help create a cleaner planet, return your used battery to the original place of purchase or your nearest Century Yuasa approved Battery Recycling Centre.

You can find your nearest recycling centre:



1300 650 702
recyclemybattery.com.au



0800 93 93 93
recyclemybattery.co.nz

For more information contact a Century battery specialist:

Australia: 49 Cobalt Street | Carole Park, QLD 4300 | T: 1300 362 287 | centurybatteries.com.au

New Zealand: 259 Church Street | Onehunga, Auckland 1061 | T: 0800 93 93 93 | centurybatteries.co.nz